

False wall by others

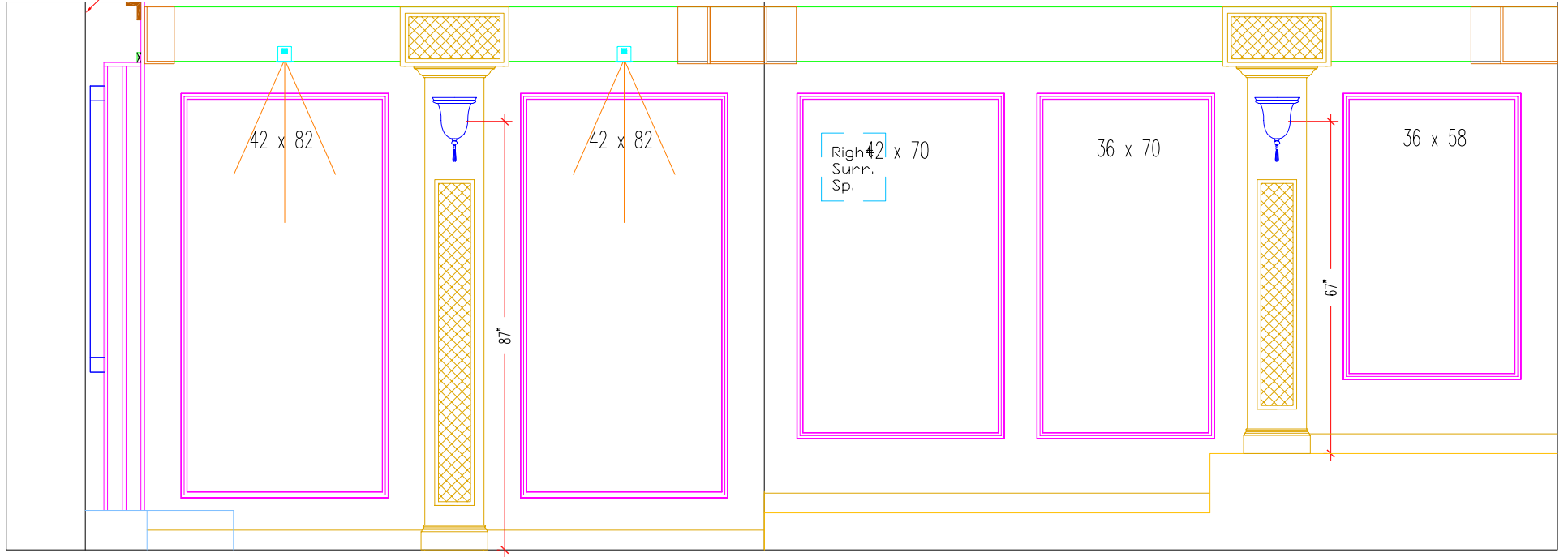

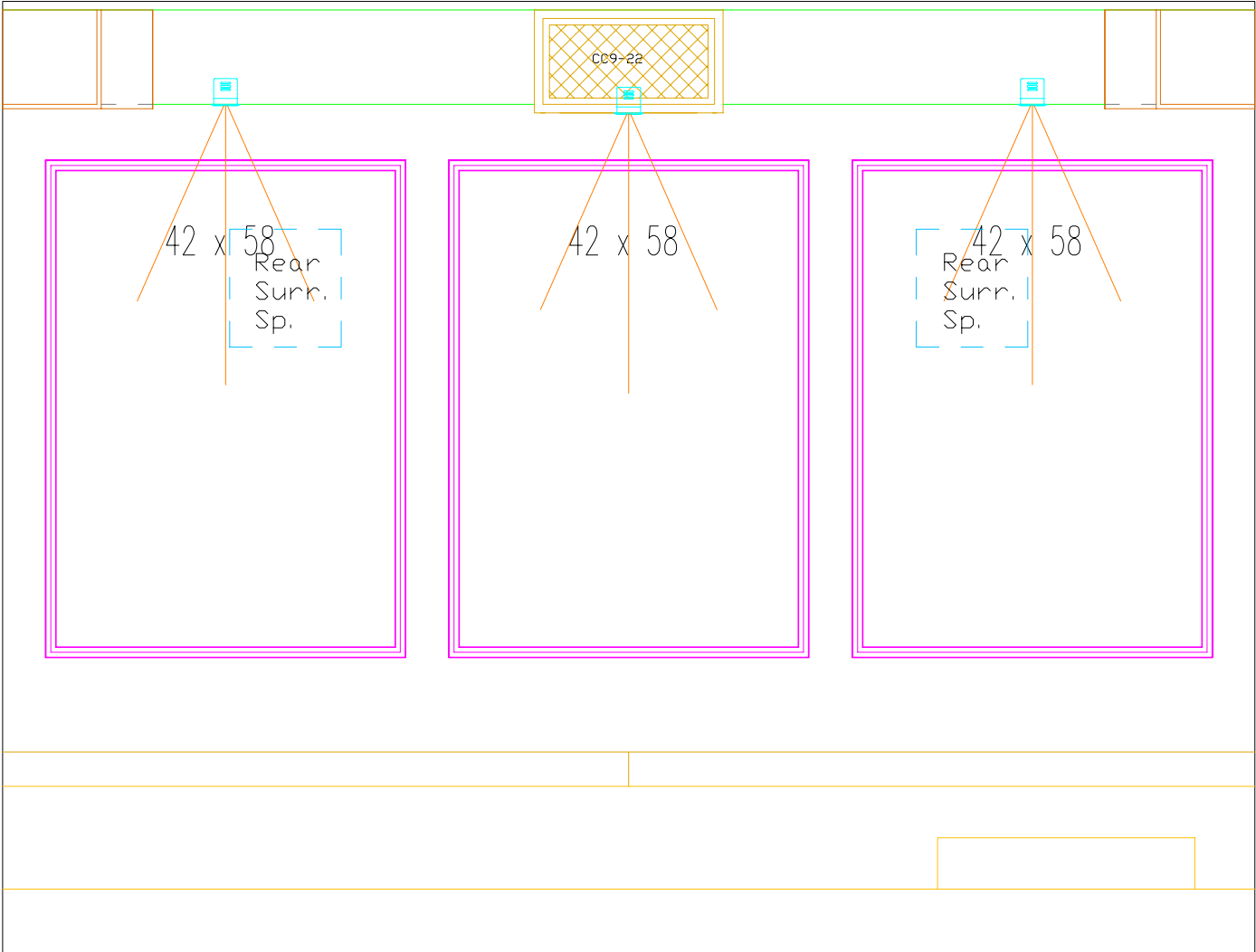

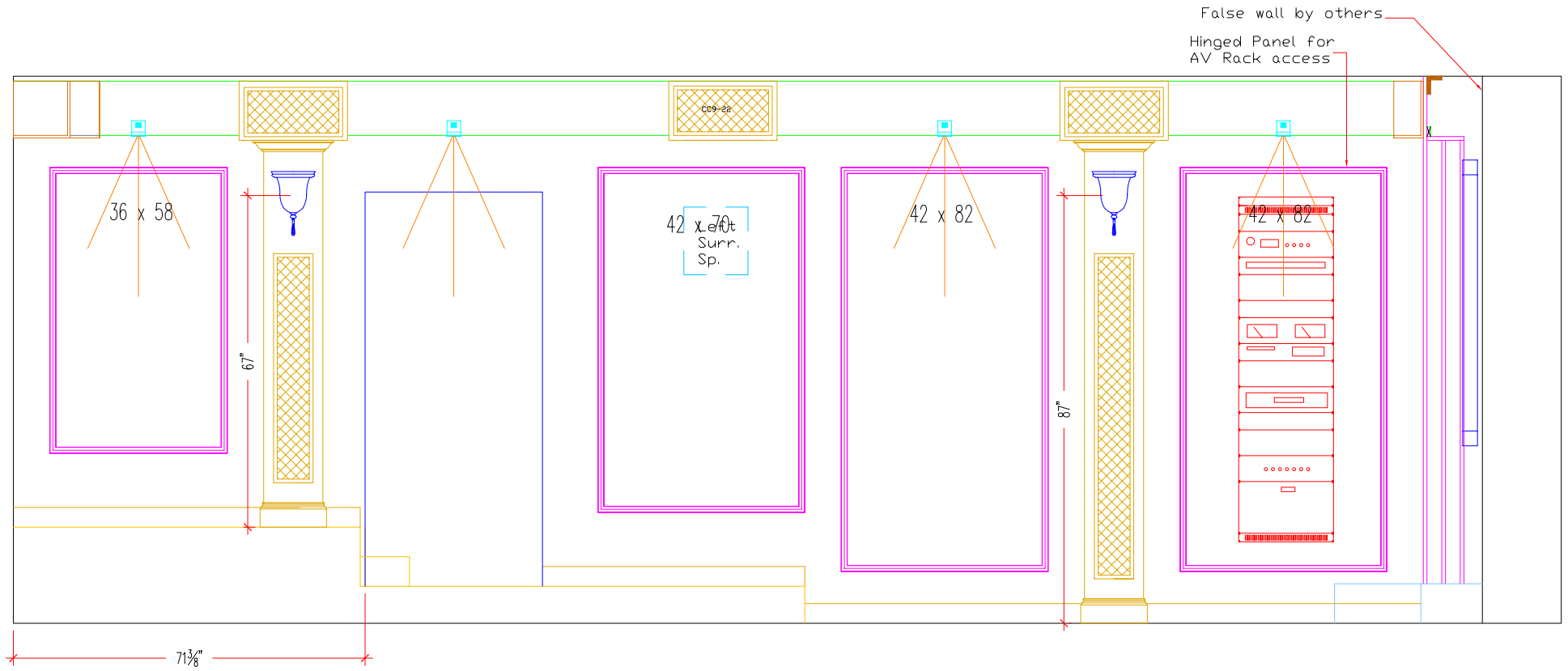

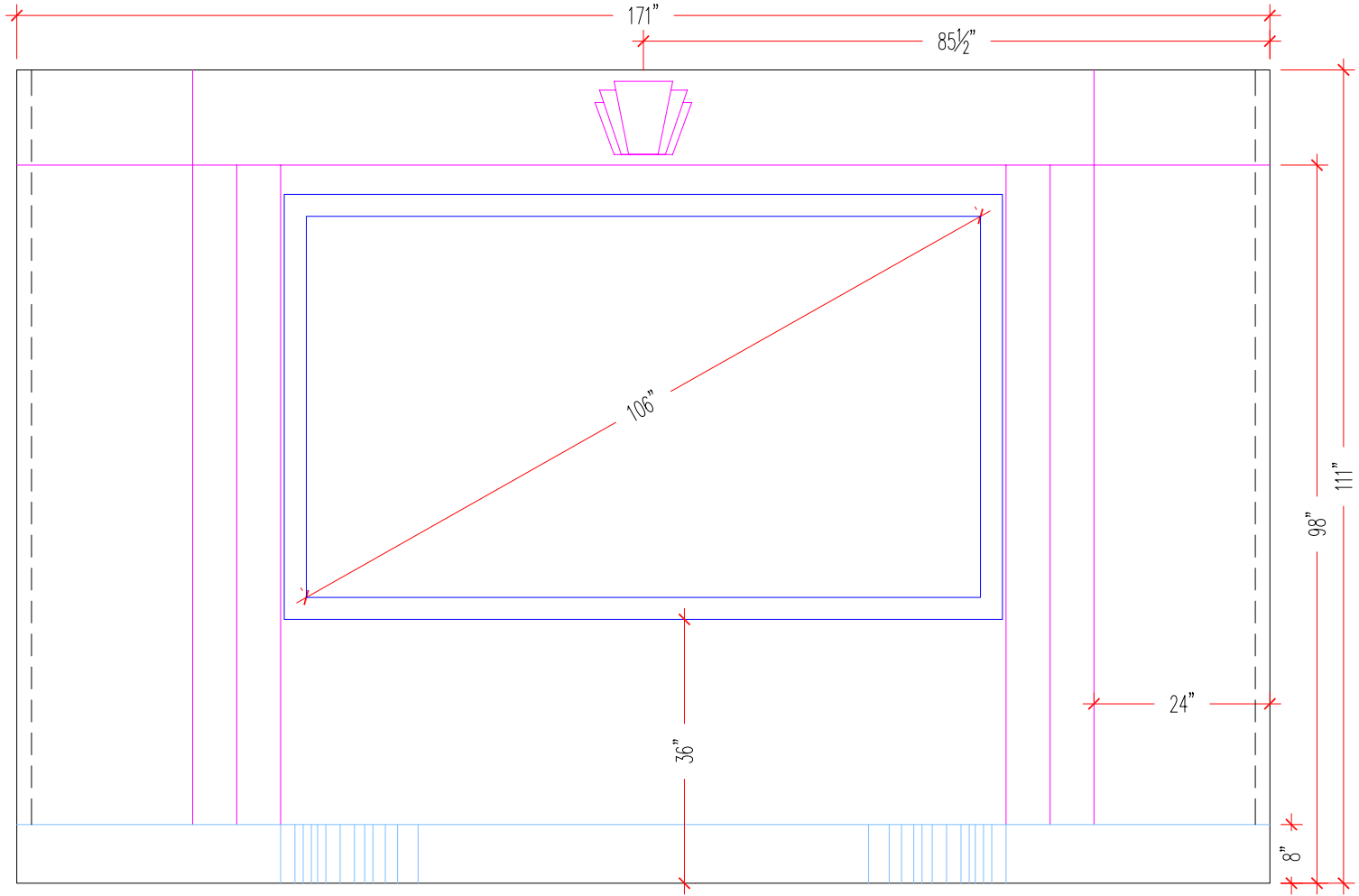

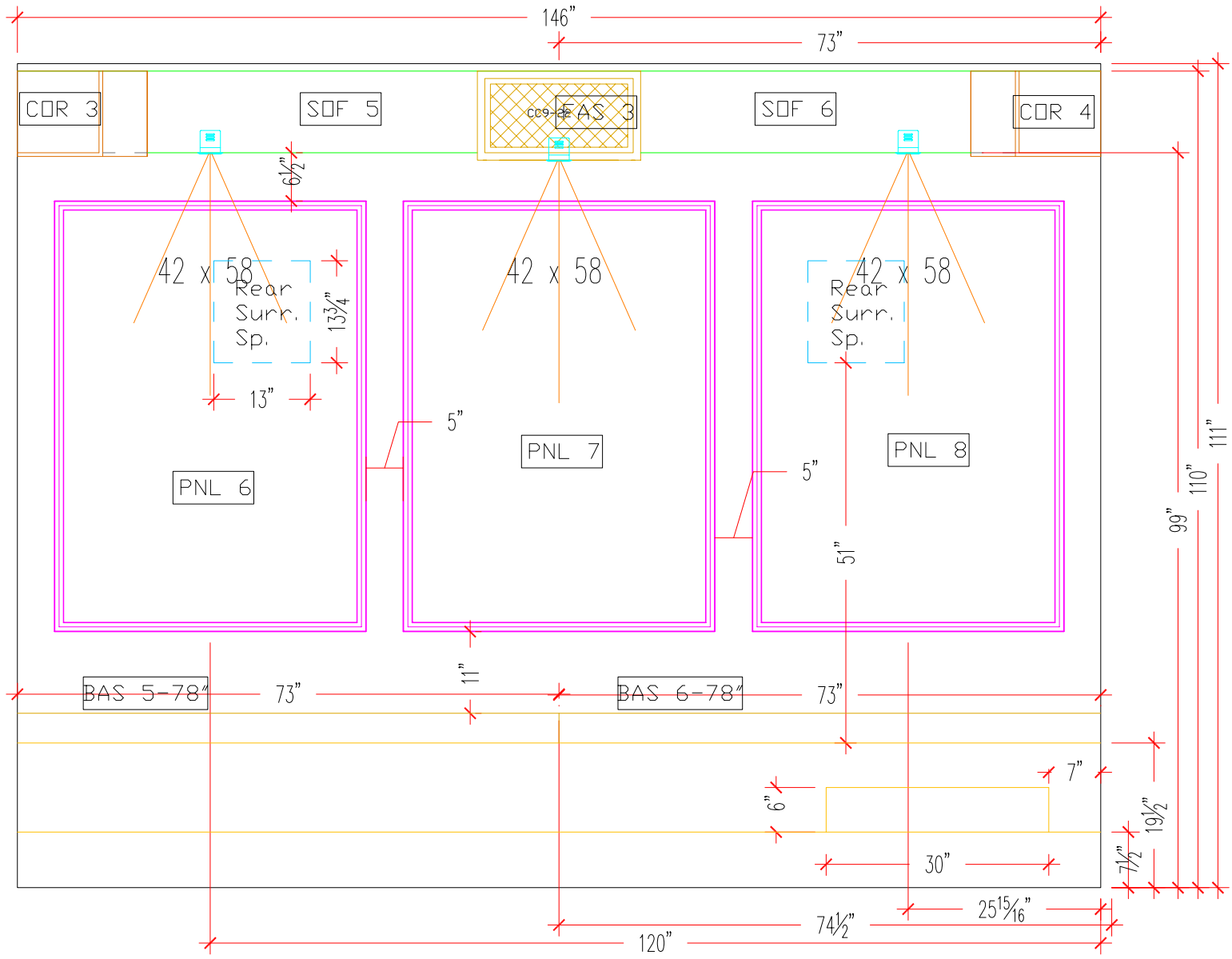

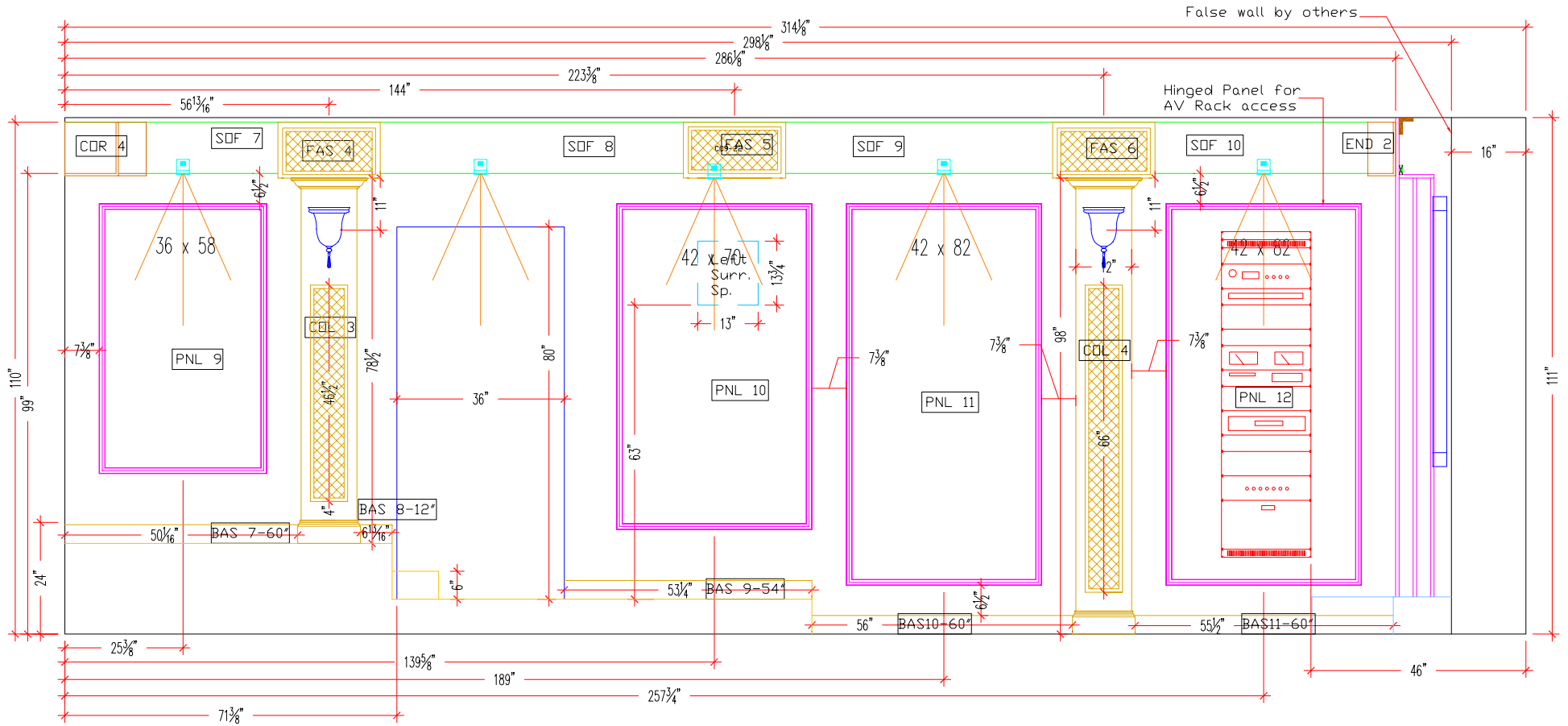

False wall by others

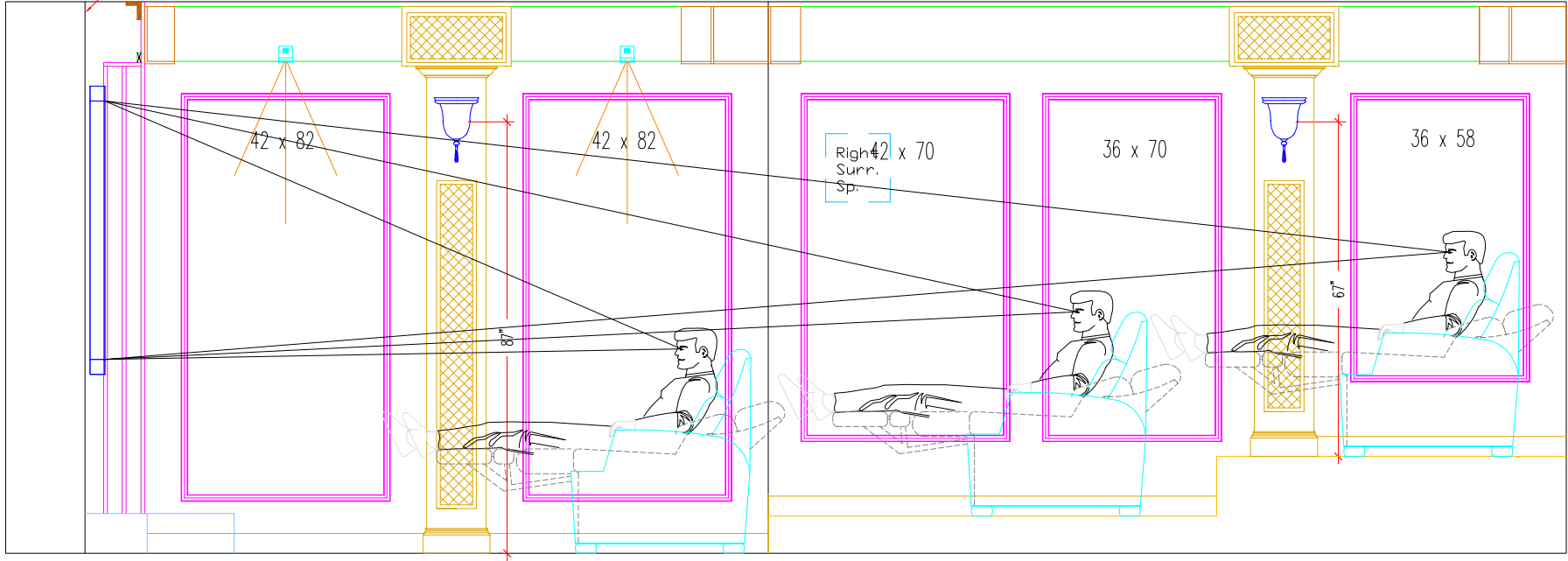

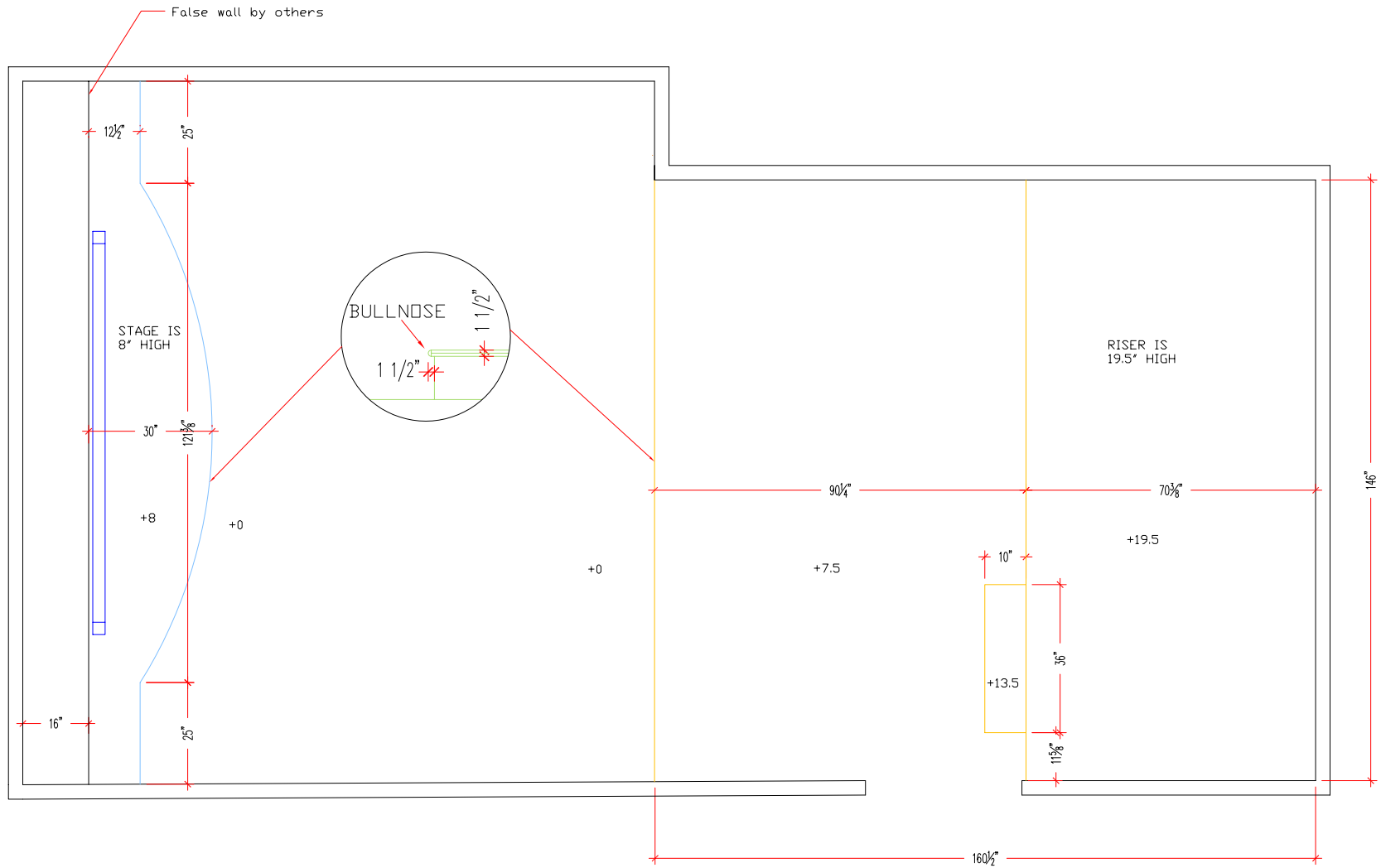

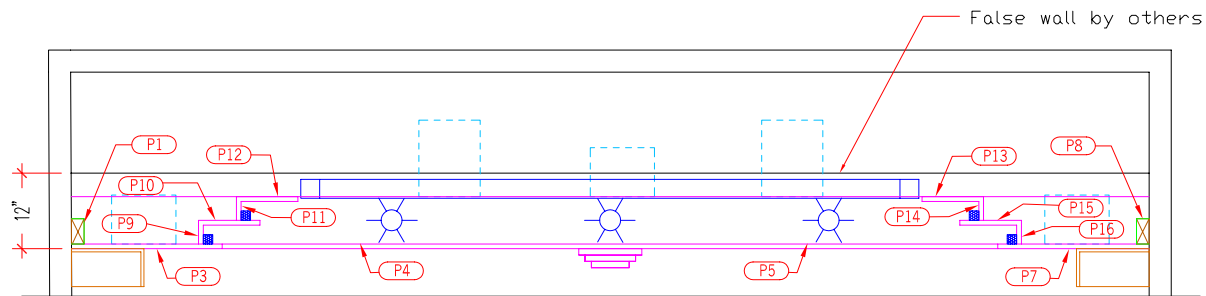

DETAIL FOR LIGHTING CIRCUIT

3 RECEPTACLES
ARE FOR SOFFIT
LIGHTS

ONE RECEPTACLE
IS FOR WALL
SCONCE

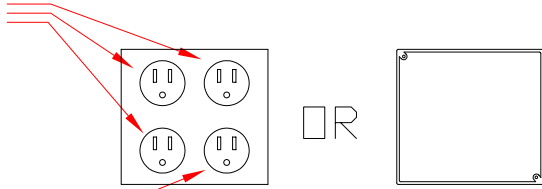

JUNCTION BOX
HARDWIRED
WITH 2
CIRCUITS

CEILING MOUNT LOCATION

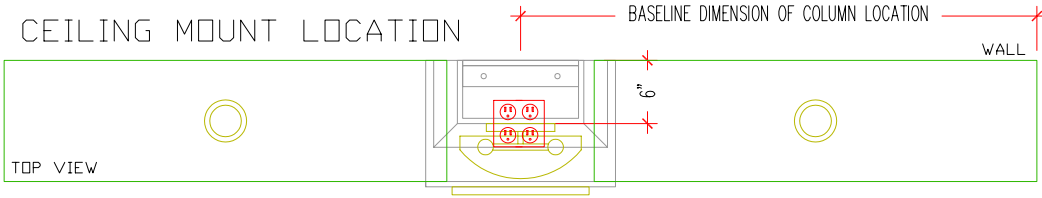

TOP VIEW

WALL MOUNT LOCATION

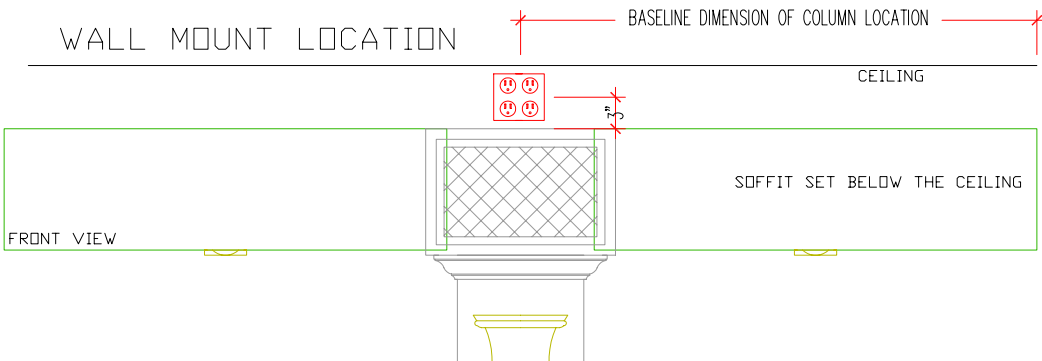

FRONT VIEW

SOFFIT SET BELOW THE CEILING

TYPICAL THEATER LIGHTING

SOFFIT LIGHTS	ZONE 1
WALL SCONCES	ZONE 2
CEILING DOWN LIGHTS	ZONE 3
STEP LIGHTS	ZONE 4
PROSENIUM LIGHTS	ZONE 5
FIBER OPTIC ILLUMINATOR	ZONE 6

ELECTRICAL FOR SOFFIT AND SCONCE LIGHTS TO BE LOCATED IN EITHER OF THESE TWO LOCATIONS DETERMINED BY WHETHER THE SOFFIT WILL BE TOUCHING THE CEILING OR BELOW THE CEILING.

CEILING DOWN LIGHTS TO BE IN THE CEILING PANELS OR WILL BE INSTALLED IN THE EXISTING CEILING BY OTHERS.

STEP LIGHTS TO BE MOUNTED CENTERED IN FACE OF RISER BY OTHERS.

PROSCENIUM LIGHTS MOUNTED IN THE SOFFIT WILL BE SIMILAR TO THE SOFFIT LIGHT ELECT.

TYPICAL CEILING PANEL RECEPTACLE LOCATION

